



Presents

BANGALORE AUTOCROSS

Name of the event	BANGALORE AUTOCROSS
Start Date of the event	10/06/2022
End Date of the event	11/06/2022
Status of the event	Open
Category	4W
Name of the Organizer	BANGALORE MOTOR SPORTS
Address	BANGALORE MOTOR SPORTS 42,1ST,FLOOR, KRISHNA NAGAR INDUSTRIAL LAYOUT, D.R.C.POST, VENKATESHWARA LAYOUT, BANGALORE-560029
Phone	9980098800
Email	bms.sports33@gmail.com
Website	website
In Association with (if any)	
Name of the Organizer	NA
Address	NA
Phone	NA
Email	na
Website	na

Supplementary Regulations

Approved by



WARNING

MOTORSPORT CAN BE DANGEROUS. DESPITE ORGANIZERS TAKING ALL POSSIBLE PRECAUTIONS UNAVOIDABLE ACCIDENTS MAY HAPPEN. YOU ARE PRESENT HERE AT YOUR OWN RISK.

TABLE OF CONTENTS

1. INTRODUCTION	4
2. ORGANIZATION	4
3. PROGRAMME	5
4. ENTRIES	6
5. INSURANCE	8
6. ADVERTISEMENT AND IDENTIFICATION	8
7. ADMINISTRATIVE CHECKS	9
8. PRE-EVENT SCRUTINEERING, SEALING AND MARKING	9
9. IDENTIFICATION OF OFFICIALS	9
11. PRIZES	10
12. PROTEST & APPEAL	10
13. RUNNING OF THE EVENT	11
14. PENALTIES	11
15. SAFETY REQUIREMENTS – DETAILED REQUIREMENTS TO BE FOLLOWED FROM THE TECHNICAL REGULATIONS/GENERAL PRESCRIPTIONS AUTOCROSS - 2022	12
NAMES AND PHOTOGRAPHS OF CRO'S	14

1. Introduction

- 1.1 The **Error! Reference source not found.** is run in compliance with the 2022 International Sporting Code of the Federation Internationale de l' Automobile (FIA), 2022 FMSCI General Prescriptions for Autocross, the relevant Technical Regulations and these Supplementary Regulations (SRs).

The Federation of Motor Sports Clubs of India (FMSCI) is the National Sporting Authority (ASN) of FIA in India.

Modifications, amendments and / or changes to these SRs will be announced only by numbered and dated bulletins, issued by the organizers, approved by the FMSCI or Stewards.

- 1.2 Acquaintance with and submission to Rules

Every person, or group of persons, organizing a competition or taking part therein

- Shall be deemed to be acquainted with all the relevant rules and regulations of the FMSCI
- All competitors must sign the indemnity and declaration form, which are enclosed with the Entry Form
- These are conditions precedent attached to the submission of entries and taking part in an event and all competitors participating shall be bound by them and also the rules and regulations hereinafter set out or amendments made thereto.
- Shall undertake to submit themselves without reserve to the above and to the decision and consequences resulting therefrom.

2. Organization

- 2.1 **FMSCI Permit No./s :**

- 2.2 **Organizers name, address and contact details**

BANGALORE MOTOR SPORTS
BANGALORE MOTOR SPORTS
42,1ST,FLOOR,
KRISHNA NAGAR INDUSTRIAL LAYOUT,
D.R.C.POST,
VENKATESHWARA LAYOUT,
BANGALORE-560029
9980098800
bms.sports33@gmail.com
website

- 2.3 **Managing Committee**

UMESH PANDEY	DEEPAK RAJU	SIRISHA VENKATRAM
PRAMOD		

- 2.4 **Organizing Committee**

UMESH PANDEY	DEEPAK RAJU	CHETAN SHIVRAM
SIRISHA VENKATRAM	RAVEE M	

2.5 FMSCI Officials

Chief Steward	
Steward	
Steward	CHIDANAND
Chief Scrutineer	MONISH

2.6 Senior Officials

Clerk of the Course	CHETAN SHIVRAM
Assistant Clerk of the Course	UMESH PANDEY
Secretary of the Meet	SIRISHA VENKATRAM
Chief Safety Officer	DEEPAK RAJU
Chief Medical Officer	
Chief Time Keeper	RAVEE M
Competitors Relations Officer	DILIP SHARAN
Media Relations Officer	
Results Co-ordinator	RAVEE

2.7 Location of HQ

From :

Day	DD / MM / YYYY	Time (hrs)	Venue
FRIDAY	09-06-2022	1000	PLAY FACTORY TRACK

To :

SUNDAY	11-06-2022	1800	PLAY FACTORY TRACK
--------	------------	------	--------------------

From :

Day	DD / MM / YYYY	Time (hrs)	Venue

To :

--	--	--	--

3. Programme

Friday 09-06-2022	
Time	Details
1000 hrs	Pre event Scrutiny
1400 hrs	Track Walk
hrs	
hrs	
hrs	

hrs	
hrs	
hrs	
hrs	
hrs	

Saturday 10-06-2022	
Time	Details
0800 hrs	Pre event scrutiny
0900 hrs	Track walk
1100 hrs	Compulsary Drivers Briefing
1130 hrs	First Stewards meeting
hrs	
hrs	
hrs	
hrs	
hrs	
hrs	

Sunday 11-06-2022	
Time	Details
1200 hrs	Start of the Autocross
1800 hrs	End of Day
1810 hrs	Provisional results
1900 hrs	Final Results
2000 hrs	Prize distribution
hrs	
hrs	
hrs	
hrs	
hrs	

4. Entries

4.1 Opening and Closing Dates

Entries open with the publication of these Supplementary Regulations
Closing date of all entries: 08-06-2022 @ 1800 hrs

4.2 Entry Procedure

Those wishing to take part in the event must send the enclosed entry form duly completed to the permanent secretariat address given in Art.2.2 prior to the closing date as mentioned in Art.4.1

4.3 Maximum number of Entries

The maximum number of entries accepted would be no more than 200. If more entries are than these are received, then the organizers reserve the right to decide which entries would be accepted.

4.4 Groups & Classes & Entry Fees

INAC 1 : Unrestricted 2WD : Petrol / Diesel

INAC 1 : Unrestricted 4WD : Petrol / Diesel

INAC 2 : Modified 2WD : NA / Turbo : Petrol / Diesel

INAC 3 : Pro Stock 2WD / 4WD : Petrol / Diesel

INAC 4 : Amateur Stock : 2WD / 4WD : Petrol / Diesel

(You may refer to General Prescriptions for suggested classes)

Sl.	Group	Petrol / Diesel	CC
1	INAC 1 2WD	Petrol	Upto 1650
2	INAC 1 2WD	Petrol	Upto 2000
3	INAC 1 2WD	Petrol	Open
4	INAC 2	Petrol	Upto 1400
5	INAC 2	Petrol	Upto 1650
6	INAC 2	Petrol	Open
7	INAC 3 2WD	Petrol	Upto 1400
8	INAC 3 2WD	Petrol	Upto 1650
9	INAC 3 2WD	Petrol	Open
10	INAC 3 2WD	Diesel	Open
11	INAC 3 4WD	Petrol Diesel	Open
12	INAC 4 2WD	Petrol Diesel	OPen
13	INAC 3 2WD	Petrol Diesel	Ladies class
14	Select	Select	
15	Select	Select	
16	Select	Select	
17	Select	Select	
18	Select	Select	
19	Select	Select	
20	Select	Select	
21	Select	Select	
22	Select	Select	
23	Select	Select	
24	Select	Select	
25	Select	Select	

Entry fees are inclusive of taxes applicable.

4.5 Payment

The entry fees can be either by demand draft in favour of **Bangalore MotorSports** payable at **Bangalore** or by cash or by wire transfer.

Name of Bank	ICICI Bank
Branch	
Nature of Account	Savings
Account No.	317805000671
IFSC Code	ICIC0003178

4.6 Refund

Entries fees will be refunded in full only

- To candidates whose entry has not been accepted
- In case of event not taking place

The organizers may refund 50% of the entry fee to those competitors who, for reasons of force-majeure (duly accepted by the organizing committee) were unable to start in the event.

5. Insurance

Organizers holding a valid 2022 FMSCI Permit for an event are covered for

Competitors : A maximum of 250 competitors with valid FMSCI Competition License participating in various events across the Country on a given day are covered for Personal Accident Insurance for Rs. 5 lakhs with Rs. 5 Lakhs medical expense extension per person.

Officials : A maximum of 100 officials officiating in various events across the Country on a given day are covered for Personal Accident Insurance for Rs.25 lakhs with Rs.1 lakh medical expense extension per person.

THESE INSURANCES ARE ISSUED BY NEW INDIA INSURANCE COMPANY LTD AND VALID DURING THE RUNNING OF THE EVENT ONLY. ORGANIZERS / COMPETITORS ARE ADVISED TO TAKE ANY ADDITIONAL INSURANCES THEY MAY DEEM FIT. IF THEY HAVE MORE THAN 100 OFFICIALS & ALSO REQUIRE DOOR TO DOOR COVERAGE PLEASE CONTACT: S.MANIKANDAN@STENHOUSE.IN

6. Advertisement and Identification

6.1 It is compulsory to carry organizers advertisement on the competing vehicles.

6.2 Competitors are allowed to affix any kind of advertisements on their vehicle provided that

- Any instructions issued by the organisers are observed.
- It is authorized by the National laws and FMSCI regulations
- Advertising must not be of a political, obscene or insulting nature. It must be in good taste and not conflict with the vehicles official numbers in any way
- It should not be placed as to prevent recognition by Officials or Marshals.
- The space designated in Appendix '4' of the General Prescription is left free of advertising other than that provided by the organisers.
- f It does not encroach upon the spaces reserved for rally plates, number plates and windscreen strips,
- It does not interfere with the driver's vision through the windows.

6.3

- The organisers will supply each crew with identification plates comprising: 2 panels carrying the race number termed COMPETITION NUMBERS. They will incorporate the race number, the name of the event and if appropriate the name of the organisers' main sponsor. They will be available as stickers.

- Competitors taking part in the Championship may elect to keep the same competition number throughout the Championship. In this case, a written request must be made to the organiser and a written acceptance taken.
- Throughout the duration of the Event, the plates must be affixed in conformity of the supplementary regulations. In no case should they cover, even partially, the vehicle's licence plates.
- The numbers plates must appear on both sides of the vehicle and be clearly visible during the entire event.
- At any time during the event, the absence or incorrect positioning of a race number plate may result in a penalty upto a maximum of INR 1,000/-.
- The competitor will be recognisable by means of an identification tag. It must carry the competitors photograph, name & blood group. Any breach noted by an official will result in a cash penalty upto a maximum of INR 1,000/-.

7. Administrative checks

7.1 Documents Submission

Entrants should produce the following for inspection at the time of submitting the vehicle for pre-event scrutiny and administrative check on the date / time as mentioned in Art.3.

Competitors are required to bring:

- Special Autocross Insurance cover valid for the dates of the event (Recommended)
- Authority letter from owner of the vehicle if the first driver / navigator not the owner of the vehicle used in the Autocross
- FMSCI Competition License for Driver (Minimum 4W Clubsport Autocross Licence. Apply online from <http://licence.fmsci.co.in/>)
- Entrant Licence / FMSCI Registration (if any)
- Pan Card copy of Competitor
- 3 Passport size photographs

Competitors are required to carry all the above documents throughout the event. All the documents shall be valid for the date of the event.

8. Pre-event Scrutineering, Sealing and Marking

8.1 Venue & Timings

Place : **Play Factory Track-Mysore road**

Date : **09-06-2022**

Time : **1000**

9. Identification of Officials

Safety Marshal	Orange
Safety Officer	Orange with white stripe and text
Post Chief	Blue with white stripe and text
Media	Green

Stage Commander	Red with text
Competitor Relations Officer	Red Jacket or Red Tabard
Medical	White
Radio	Yellow with blue mark
Scrutineer	Black

11. Prizes

All classes will receive trophies for the top three drivers in their respective classes, fastest driver and best tuner award will also be given

12. Protest & Appeal

12.1 LODGING A PROTEST OR APPEAL

All protests and / or appeals must be lodged in accordance with the stipulations of Articles 13,14 and 15 of the Code.

12.2 PROTEST FEES

12.2.1 For Closed, Closed Invitation and Open Events, the protest fees is ₹7,080/= (Rupees Seven Thousand Eighty Only) (₹6,000/= +₹1080 GST). For Challenge, Cups, Series, Trophy and League events, the protest fee is Rs.14,160/- (Rupees fourteen thousand one hundred sixty only)

12.2.2 If a protest requires the dismantling and re-assembly of a clearly defined part of the car any additional deposit of Rs. 10,000 or will be specified by the Stewards upon a proposal of the FMSCI Technical Delegate / Chief Scrutineer.

12.2.3 If the protest is overruled or it is withdrawn after being brought, no part of the fee shall be returned. (Article 13.10.1 of FIA International Sporting Code)

12.2.4 If it is proved that the author of the protest has acted in bad faith, the FMSCI may inflict upon them one of the penalties laid down in the Code. (Article 13.10.3 of sporting code)

12.3 APPEALS

₹113,280/= (Rupees One Lakh Thirteen Thousand Two Hundred Eighty Only) (₹96,000/= +₹17,280/= GST)

- Competitors may appeal against decisions, in accordance with the stipulations set out in Articles 15.1 of the Code.
- Competitors have the right to appeal against a sentence or other decisions pronounced on them by the Stewards of the meeting. They must, however under pain of forfeiture of their right to appeal, notify the Stewards of the Meeting in writing within one hour of the publication of the decision, of their intention to appeal.
- The right to bring an appeal expires 96 hours from the moment the stewards are notified of the intention to appeal on condition that the intention of appealing has been notified in writing to the stewards within one hour of the publication of the decision. This grounds of appeal may be brought by fax or by any other electronic means of communication with confirmation of receipt. Confirmation by a letter of the same date accompanied by the necessary fee is required. The FMSCI will give its decision within a maximum of 30 days.
- All parties concerned shall be given adequate notice of the hearing of any appeal. They shall be entitled to call witnesses, but their failure to attend the hearing shall not interrupt the course of the proceedings.

- The confirmation of an appeal to the FMSCI must be accompanied by a fee of ₹113,280/= (Rupees One Lakh Thirteen Thousand Two Hundred Eighty Only). **FMSCI Bank details below:**

Account Holder: The Federation of Motor Sports Clubs of India
SB Account No: 801010100003491
Name of Bank: Bank of India, Adyar Branch, Chennai-600020
RTGS / IFSC Code: BKID 0008010

- This fee becomes due from the moment the appellant notifies the Steward of the intention of appealing, and remains payable even if the appellant does not follow up the declared intention to appeal.
- If the appeal is rejected or it is withdrawn after being brought, no part of the fee shall be returned.
- If judged partially founded, the fee may be returned in part, and in its entirety if the appeal is upheld.
- If it is proved that the author of the appeal has acted in bad faith, the FMSCI may inflict upon them one of the penalties laid down in the Code.

13. Running of the Event

The event will be run according to the INAC championship regulations

The event will use digital means of timing

the event will use whats app and a notice board as the official menas of communication

The event will be run on Gravel

14. Penalties

REASONS	START REFUSED	DISQUALIFY	PENALTY	DNF
Entry Fees not Paid	Yes			
Documentation Incomplete		Yes		
Not carrying advertisements as per Appendix I	Yes			
Inability to produce Race Card at start	Yes			
Late sign-in on qualifying morning			Cash Fine of Rs: 750/-	
Scrutineering				
No seat belts		Yes		
Seats Not Fixed Properly		Yes		
Head Lights Not working		Yes		
Bad Tyres and Brakes		Yes		
Loose items in car	Yes			
Missing Helmet		Yes		
Helmet not strapped properly	Yes			
Driver side Window not closed		Yes		
Not wearing gloves			Cash fine of Rs: 2,000/-	
Late at Start by 5 minutes		Yes		

Over speeding or doing unsafe practice rounds in and around Auto - cross premises/ roads		Yes		
Unsporting Manner		Yes		
Identification Marks		Yes		
Fraud		Yes		
Travel in opposite direction		Yes		
Car unable to start within 20 secs at start line		Yes		
Over speed after stop finish line		Yes		
False Start (upto 2 secs)				
1 st Offense			5 secs	
2 nd Offense			10 secs	
3 rd Offense		Yes		
False start more than 2 secs		Yes		
Missing/ Displacement of a / slalom marker marked by a different colour/per marker			5 secs	
Breach of track			5 secs	
Leaving track & gaining unfair advantage		Yes		
Unauthorised driver		Yes		
Hitting time control/timing equipment or marshal stations		Yes	Cost of timing equipment as decided	

15. Safety Requirements – Detailed requirements to be followed from the Technical Regulations/General Prescriptions Autocross - 2022

DRIVERS SAFETY:

No driver will be allowed to take part in any official practice, qualifying or race unless they have the following:

- Driver should wear suitable clothes; Shorts are not permitted. A Driving Suit is recommended. Driving gloves is compulsory.
- During the event, all drivers participating should wear a Branded BIS (minimum) marked Safety Helmet and shall be properly harnessed in the seat belt. The helmet chin strap should be securely fastened while competing.
- Footwear should be such that shoes covering the entire foot shall be worn.
- All loose items, inside and outside the car, must be removed. Hand held items, such as but not limited to, cameras and cell phones are considered loose items.
- The driver side and left side windows must remain at least three quarters closed during his run. The back-side windows may be left open in rainy conditions.

VEHICLE COMPLIANCE

Refer the FMSCI Technical Regulations 2022 for Autocross for more detail.

EVENT SAFETY

SAFETY Ambulance:

Minimum well equipped 1-trauma care ambulance with doctors and one more ambulance to transport the injured to a nearby hospital.

Barricading:

All spectator areas should be well cordoned off. None other than the competitors, pit /service crews and officials shall be present in the pits and other race areas.

Fire Tender & Fire Extinguishers:

A fully equipped fire tender should be present during official practice and races. Adequate number of fire extinguishers should be placed at parc fermes, pits and Marshall Posts at the track. In case a fire – tender is not available; the Steward's can inspect the available number of extinguisher's and give the go ahead if they feel it is adequate.

Communication:

Wireless Communication is a must between officials, post marshals and ambulances.

Security:

Enough security persons should be deployed to control the crowd from entering in to the pits and racetrack.

Names and photographs of CRO's

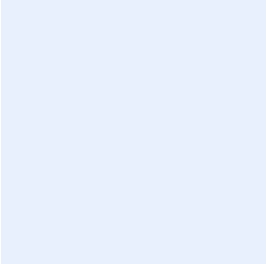
	
DILIP SHARAN	CRO NAME
8861453803	MOBILE
email	email

Will be present at:

- At the Secretariat.
- At the start of the scrutineering.
- Near the "PIT AREA".

NOTES / WAIVERS

APPENDIX 1: COMPETITION NUMBERS & ADVERTISING

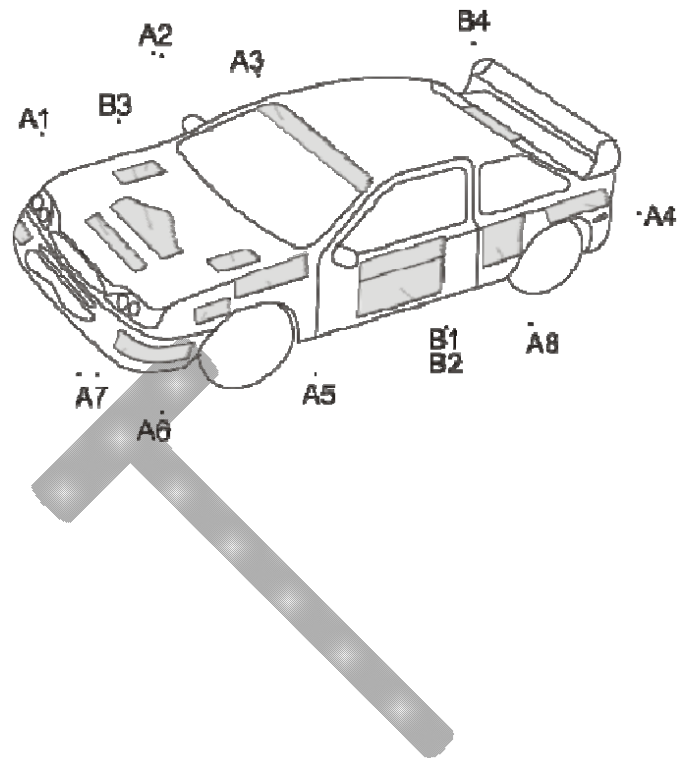

- A1 : TBA
- A2 : Club/Sponsor
- A3 : Sponsor
- A4 : Sponsor
- A5 : TBA
- A6 : TBA
- A7 : TBA
- B1 ~ B3: Competition Number

PROTEST FORM

Name of Event		Date	
Organizer		Venue	
Status		Permit No.	

Name of the Competitor	
Competition Licence No.	
Competition Number in the event	
Reason for Protest	

To: The Chairman of Stewards

Details of Protest	
--------------------	--

Fees Enclosed			
Signature			
Date		Time	

INTENTION TO APPEAL FORM

Name of Event		Date	
Organizer		Venue	
Status		Permit No.	

Name of the Competitor	
Competition Licence No.	
Competition Number in the event	
Against Stewards Decision No.	

To: The Chairman of Stewards

I / We hereby file our Intention to Appeal to the Indian Motor Sports Appeal Court against the Stewards Decision No. mentioned above.

Signature			
Date		Time	